

ON THE SENSITIVITY OF THE CHEMORECEPTORS ON THE ANTENNA AND FORE-TARSUS OF THE HONEY-BEE, *APIS MELLIFICA* L.

By JOSEPH MARSHALL, M.Sc., A.R.C.S.

(Entomology Department, Rothamsted Experimental Station.)

(Received 10th July, 1934.)

(With Three Text-figures.)

THE experiments to be described were undertaken as a preliminary study of the reactions of the contact chemoreceptors on the antenna and fore-tarsus of the honey-bee, *Apis mellifica* L., to various concentrations of sucrose solutions. Experiments were also carried out to estimate the effect of antennal amputation on chemotropic response.

I. SENSITIVITY OF THE CONTACT CHEMORECEPTORS OF THE ANTENNA AND FORE-TARSUS.

The experiments were designed to determine the critical dilution of sucrose which would elicit a response when brought into contact with the antenna, as well as to find out the dilutions that would obtain a like response on the fore-tarsus. The criterion of response was the complete extension of the proboscis.

Minnich (1921-32) has demonstrated that the tarsal joints of many insects (certain butterflies, muscid flies and bees) possess contact chemoreceptors which serve as organs of taste. Minnich used insects with extensible mouthparts, and recorded a response on the extension of these organs after the stimulus had been given. The sensitivity of the contact chemoreceptors in certain butterflies is such that they respond to a $1/6400M$ solution of saccharose though at the same time showing no response to distilled water. Verlaine (1927) disagreed with some of Minnich's results with *Pieris rapae*. He failed to obtain the regular extension observed by Minnich and accounted for many of Minnich's results in terms of stimulation by water vapour, tactile stimuli dependent upon viscosity, and mechanical stimuli brought about during the course of the treatment. Since all Minnich's results were based on response, only after water had failed to elicit a response, water vapour cannot be regarded as the cause of the response. It is on this assumption that the whole technique rests. Nor can the viscosity of the solutions be an influencing factor, since, as Minnich points out, the order of effectiveness of the solutions as tarsal stimuli was:

Water < $2M$ NaCl < $1/3200M$ saccharose < $1M$ saccharose,

the order of relative viscosity being:

Water < $1/3200M$ saccharose < $2M$ NaCl < $1M$ saccharose.

On the same evidence osmotic pressure is also ruled out. When considering the effect of mechanical stimuli, Verlaine claimed that a response was obtained by lifting one of the tarsi by means of a dry spatula. Since all Minnich's responses were only taken after a like test (differing only in use of water instead of sucrose), had failed to give any response, mechanical stimuli are ruled out. It may therefore be assumed that Minnich's work and the conclusions which he reached are substantially correct. They have since been confirmed by Abbott (1928), Weiss (1930), Crow (1932) and Anderson (1930).

After the writer's experiment had been started it was found that Minnich (1932), also using the extension of the proboscis in the honey-bee as a response, had discovered that bees trained on $64/100M$ saccharose solution, responded when a similar solution was brought into contact with the antenna and the foreleg. The hindleg only responded in a few cases.

The bees used in these experiments were obtained from the apiary at Rothamsted Experimental Station and were normal in every respect. Unlike those used in Minnich's experiment these bees were not previously trained to feed on sugar solutions.

Difficulty was experienced in mounting the bees so that the antennae did not interfere with tests carried out on the forelegs. Finally two slotted pieces of card were placed round the neck of the animal as illustrated in Fig. 1. The advantage of this method of mounting over the method adopted by Minnich (who mounted the dorsal side of the insect in a block of wax), lies in the fact that the antennae are at a reasonable distance from the forelegs, and cannot therefore interfere with tests concerned with the tarsi only. Placing cards round the neck does not alter the condition of the bee, whereas mounting in wax, although it may not affect the results, adds possible complications. Minnich, in any experiments on the response of the leg, first amputated the antennae in order to eliminate the possibility of their touching the legs. With the method of mounting used in this experiment no such precaution was necessary, although in one instance the antennae were removed to see if any effect was exercised on the response of the leg.

Once mounted, the bees were fed with water until no further response was obtained. In most cases the bees rarely responded to water and were soon satisfied. Minnich emphasised the necessity of restricting observations to bees which are unresponsive to water, consequently before any test was made with the sucrose solutions care was taken to ensure that the bees did not respond to distilled water.

Solutions of sucrose of strengths ranging between $M/1$ and $M/24$ were freshly prepared using distilled water. The solutions were presented to the antenna or the fore-tarsus by lightly touching the part to be tested with a camel's hair brush, which was moistened with the solution. Groups of twelve bees were taken at one time and a response was recorded if a proboscis was extended within ten seconds of

the application of the sucrose solution. The different solutions were offered at intervals of twenty minutes.

The solutions were offered in two ways; in the first case the stronger solutions were offered at the commencement of the experiment, and the weaker solutions were offered in turn after lapses of twenty minutes; in the second instance the reverse procedure was tried, and the weaker solutions were offered first. This

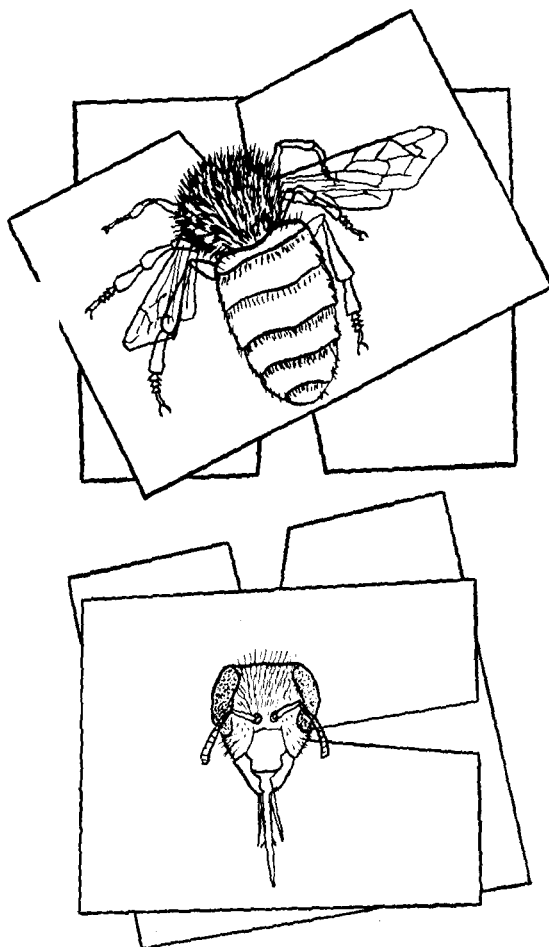

Fig. 1. Method used for mounting the bees during threshold experiments.

procedure makes it improbable that any interference due to the recollection of the previous experience would be present. It was found that there was no difference in the results of the two sets of observations.

Altogether 100 bees were treated and the threshold value of a sucrose solution for each bee (that is the weakest solution which gave a response) was recorded. The results are given in Table I where bees are grouped according to the weakest solution to which they responded.

Von Frisch (1927, 1928) found that, in the field, bees recognise dilutions of saccharose between the limits $M/4$ and $M/8$. From the results given below it would seem that the average threshold value is about $M/12$. In some cases, however, responses occur to solutions considerably weaker as well as stronger than those of the mean value. A definite figure for the threshold value must be regarded with due caution, as it rests essentially on an arbitrary basis and must depend largely

Table I. *Threshold values of sucrose solutions which stimulate the antenna of the honey-bee, positive response being measured by extension of the proboscis.*

Concentration	$M/4$	$M/6$	$M/8$	$M/10$	$M/12$	$M/14$	$M/18$	$M/24$
Distribution of bees	2	12	11	13	28	14	11	9

Concentration = strength of sucrose solution.

Distribution = no. of bees, out of a total of 100, where threshold response is at the indicated concentration.

on the condition of the particular insect in each case, but it forms a convenient means of estimating the average sensitivity of response of the population.

In order to ascertain whether there was any difference in the rate of reaction to varying concentration twenty bees were offered solutions of $M/4$, $M/6$, $M/8$ and $M/12$, and the time taken for the bees to respond to each was recorded. The entire experiment was completed within one and a half hours in order that the condition of the bees should remain constant throughout all the trials.

Table II.

Concentration of the solution	$M/4$	$M/6$	$M/8$	$M/12$
Average time taken to respond (seconds)	3.5	4.6	4.6	3.6

These results indicate that the response to a stimulus takes place within the same space of time even though the strength of the applied stimulus may vary. Unfortunately the test could not be applied to the higher dilutions owing to the large number of bees that became excluded from the test owing to their threshold values being above $M/12$.

On applying different concentrations of the sucrose solutions to the tarsi of the forelegs and taking the proboscis extension as a sign of positive response the results recorded in Table III were observed.

Table III. *Threshold values of sucrose solutions which stimulate the fore-tarsus of the honey-bee, positive response being measured by extension of the proboscis.*

Concentration	$M/4$	$M/2$	$M/1$
Distribution of bees	0	6	21

Four bees failed to respond.

"Concentration" and "distribution" as in Table I.

It is clear from these results that it requires a $M/1$ concentration to stimulate the contact chemoreceptors of the fore-tarsus, whereas the antenna are sensitive to much more dilute solutions.

II. CHEMOTROPIC RESPONSES BEFORE AND AFTER ANTENNAL AMPUTATION.

Experiments were carried out to see whether the olfactory powers of the honey-bee were lost after antennal amputation, when the conditions of the experiment were rigidly controlled and only mild odours were used.

A survey of the literature of the subject might indicate that further work would serve no useful purpose. Nevertheless there is a need for experiments which, as far as possible, eliminate conflicting factors, and which are conducted under constant

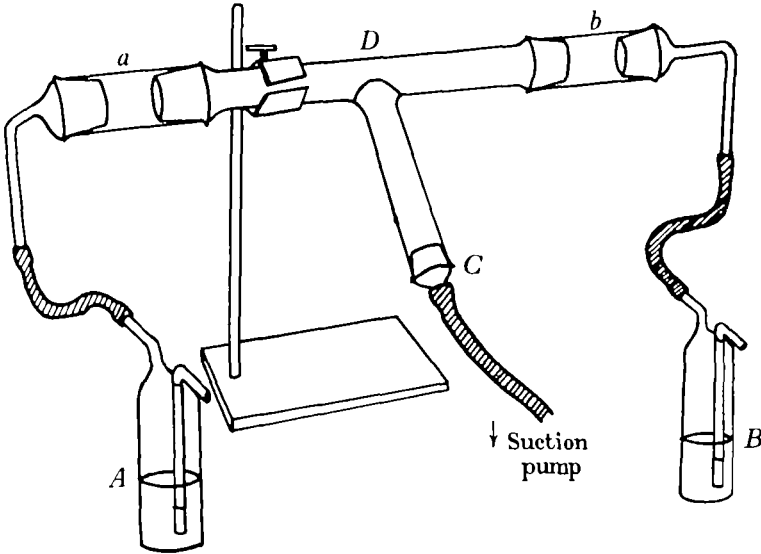

Fig. 2. Type "A" olfactometer.

and approximately natural conditions. The nature of the attracting substance used is of the first importance. It is essential that it should be a substance which enters into the normal environment of the insect, and at the same time it should exert a strong attractive effect. If a substance having a weak olfactory attraction is used, there is a danger of the results becoming confused. There are two important considerations: (a) the substance used as the olfactory stimulant must exert a strong positive attraction without acting as an irritant or affecting a non-olfactory receptor; (b) the conditions of the experiment must aim at eliminating all other extraneous factors.

The first group of experiments was conducted using honey as the attractive substance. The type of apparatus used was the olfactometer shown in Fig. 2. Air currents were drawn through a strong solution of honey at one end of the apparatus (A) whilst, at the end B, air was drawn through distilled water as the control.

Bees were introduced at *C*, one at a time. After the bees had been placed in the apparatus they walked to the junction *D*, where they were confronted with the choice of two directions. To allow for possible random wanderings no record was taken until the bees had entered one of the chambers *a* or *b*. When a bee had finally entered one of these chambers the result was recorded, the bee removed, and another bee was introduced into the apparatus.

Using the olfactometer as shown in Fig. 2 and introducing one bee at a time the results recorded in Table IV were obtained.

Table IV. *Chemotropic responses of the honey-bee. Air which had passed through honey solution was used as the attracting substance and air passed through distilled water as a control.*

No. of bees	No. of bees entering honey chamber	No. of bees entering control chamber
Exp. i, 50	32	18
Exp. ii, 25	14	11
Exp. iii, 25	9	16
Total 100	55	45

No preferential attraction to the honey is indicated from these results.

Although the results of the above trial do not show any attraction for honey, a further experiment was carried out with bees whose antennae had been removed. Removal of the antenna was effected after anaesthetising the bees with chloroform.

Table V. *Chemotropic responses of the honey-bee, after antennal amputation. Conditions as in Table IV.*

No. of bees	No. of bees entering honey chamber	No. of bees entering control chamber
Exp. i, 25	11	14
Exp. ii, 25	12	13
Total 50	23	27

These results are of the same order as the results obtained on the normal bees in the previous experiment.

It was clear that the honey solution was not attracting the bees. An experiment,

Table VI. *Chemotropic responses of the honey-bee, air passed through honey solution was used as the attracting substance and air passed through phenol solution as the alternative.*

No. of bees	No. of bees entering honey chamber	No. of bees entering phenol chamber
25	14	11

in which a phenol solution replaced the control of distilled water, was then carried out. Since honey itself did not attract, the repellent effect of the phenol might drive the bees into the honey chamber. The use of such a strong-smelling substance is open to many objections and the experiments were not extended. The results are given in Table VI.

Obviously no powerful repellent effect due to the phenol is shown.

These experiments are not immune from criticism, as the olfactometer used had many drawbacks. The bees generally were very slow in leaving the limb *C* even though the only source of light came from the directions of *a* and *b*. This delay seriously prolonged the duration of the experiment, as only one bee at a time could be dealt with. The use of honey as the attracting substance was a complete failure. Considering the matter from a teleological standpoint, the main desire of the bees would be to escape, and so offering honey, at a time when they had no desire for food, effected no response. The bees might have realised the presence of a stimulating substance and yet have failed to respond. From preliminary experiments it

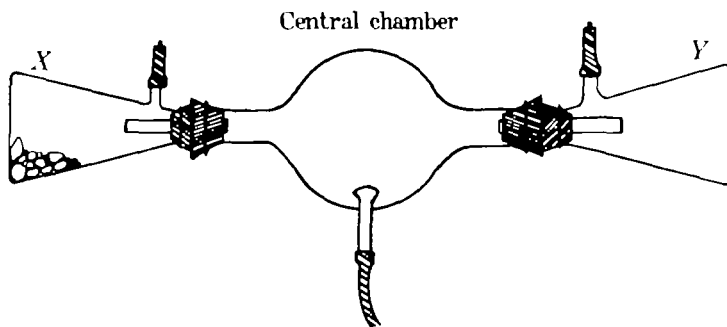

Fig. 3. Type "B" olfactometer. (Capacity of central chamber 600 c.c. approx.)

was found that a bee could differentiate very small differences of light intensity—being attracted to the stronger source irrespective of the honey odour. Whatever attraction honey has for the bee is completely masked by other factors. Therefore, it was necessary to obtain some other attracting substance and also to improve the apparatus used in the tests. In an attempt to find this substance, wax, which had come from a hive, was used and found to have very strong attractive properties.

Beeswax obtained from the apiary was used as the attracting substance. Since the first type of olfactometer proved to have many drawbacks another type was used in which insects were placed in a central chamber and allowed to orientate themselves according to the diffusion currents set up by the attractive substance. The apparatus, Fig. 3, consisted of a central chamber with two exits, leading to two flasks. In one of these flasks was placed the broken up wax. The entrances into the flasks were such that bees could not return into the central chamber once they had entered the flask. The apparatus was operated in a dark room at a constant temperature of 21° C. and at a humidity of 50 per cent. Bees were taken from the same hive and if they were fed on a little honey it was found that they lived for several days. After feeding, the bees were placed in the central chamber and put in the

dark room where they were allowed to acclimatise themselves for two hours. Bees, after this period, were active and the flasks *X* and *Y* were then placed into position. Counts were taken when the bees had ceased to leave the central chamber.

Experiments were also carried out on bees whose antennae had been removed. Normally this operation was performed after the bees had been chloroformed, but as a check one trial was made where no chloroform was used. The duration of the experiments varied from two to sixteen hours. A few strips of filter paper placed in the flasks kept the bees healthier as it enabled them to have a substratum on which to crawl.

Table VII. *Chemotropic responses of the honey-bee with "type B" olfactometer using beeswax as the attracting substance. The bees are under conditions of darkness, at a temperature of 21° C. and a humidity of 50 per cent.*

No. of bees	No. of bees left in central chamber	No. of bees in wax chamber	No. of bees in empty chamber
25	8	16	1
50	12	37	1
25	6	15	4
Total 100	26	68	6

As a control, the same experiment was conducted with no wax in either flask, both being empty.

Table VIII. *Results from a control experiment where bees were introduced into "type B" olfactometer under the conditions given in Table VII, but with both flasks empty.*

No. of bees	No. of bees left in central chamber	No. of bees in flask <i>X</i>	No. of bees in flask <i>Y</i>
50	33	8	9

That the bees seek out the wax by means of their olfactory powers is clear. This response affords an excellent means of studying the effect of antennal amputation on the olfactory response, as shown in Table IX.

The most efficient method of removing the antennae was to cut off the antennae by scissors after anaesthetisation with chloroform.

The results of this experiment prove conclusively that, under the conditions of the experiment, the loss of the antennae brings about total loss of olfactory power. The effect of using chloroform seems to have no prejudicial influence on the insect's response. The bees used in the experiments lived for several days after they had left the hive, and if this is any means of judging their normality the insects may be regarded as normal.

The results of the experiments on the threshold values of sucrose solutions which elicit a response, demonstrate that the antennae normally respond to dilutions

2. Amputation of the antenna does not impair the normality of the bee in respect of its gustatory reactions.

3. By strictly controlling the conditions of the environment of the experiment and by using a modified type of olfactometer, results are obtained showing a significant attraction to hive wax.

4. Amputation of the antennae results in a complete loss of olfactory recognition of the wax, and it is concluded that the antennae are the seat of all the olfactory organs which perceive mild odours.

ACKNOWLEDGMENTS.

The writer wishes to thank Sir John Russell for permission to work at the Rothamsted Experimental Station and to express gratitude to Dr C. B. Williams for the help and interest he has shown in the work.

Acknowledgment is made of the generous help and criticism afforded by Mr H. C. F. Newton and of the assistance of Miss A. M. Lysaght in reading the manuscript.

The author also wishes to thank Mr D. Morland for bees obtained from the apiary.

The work was carried out during the tenure of an Empire Cotton Growing Corporation Scholarship.

REFERENCES.

- ABBOTT, C. E. (1928). *Psyche*, **35**, 201-4.
 ANDERSON, A. L. (1930). *Anat. Rec.* **47**, 288-89.
 CROW, S. (1932). *Physiol. Zool.* **5**, 16-35.
 FRISCH, K. VON (1927). *Naturwissenschaften*, **15**, 1-20.
 — (1928). *Naturwissenschaften*, **16**, 307-15.
 MINNICH, D. E. (1921). *J. exp. Zool.* **23**, 173-203.
 — (1922a). *J. exp. Zool.* **35**, 57-81.
 — (1922b). *J. exp. Zool.* **36**, 445-57.
 — (1926a). *Biol. Bull. Wood's Hole*, **51**, 166-78.
 — (1926b). *Anat. Rec.* **34**, 126.
 — (1929a). *Z. vergl. Physiol.* **2**, 1-55.
 — (1929b). *Quart. Rev. Biol.* **4**, 100-12.
 — (1931). *J. exp. Zool.* **60**, 121-39.
 — (1932). *J. exp. Zool.* **61**, 375-93.
 VERLAINE, L. (1927). *Ann. Soc. ent. Belg.* **67**, 147-82.
 WEISS, L. (1930). *Z. vergl. Physiol.* **12**, 206-48.

of the order of $M/12$, never failing to respond to $M/6$ and, in some instances, do so to $M/24$. On the other hand the fore-tarsi require a concentration of at least $M/2$. To understand this difference it is first necessary to ascertain the sense or senses which actuate the response. The difference cannot be due to the stimulation of the organs of touch, since each test was always preceded by an identical test, using distilled water, which yielded no response. The point at issue is whether the

Table IX. *Chemotropic responses of the honey-bee using "type B" olfactometer with beeswax as the attracting substance. The antennae of the bees were removed with and without previous treatment with chloroform. Conditions as before.*

No. of bees	No. of bees left in central chamber	No. of bees in "wax" chamber	No. of bees in control chamber
Without chloroform			
25	11	7	7
25	9	6	10
Total 50	20	13	17
Using chloroform			
25	11	6	8
25	10	9	6
50	28	9	13
100	49	24	27
Total 150	69	37	44

same type of sense organs is affected in the case of the antennae as in the fore-tarsi. If, in both experiments, only the taste organs are stimulated, then the antennae must be able to recognise the more dilute solutions because they have situated upon them taste organs of greater perception. If this difference is not due to the existence of more refined taste organs on the antennae, it may be due to the activity of organs which normally perceive olfactory stimuli. If this suggestion is correct, there can be no rigid barrier between the conception of the two senses, taste and smell, since the olfactory organs on the antennae function in the reception of taste stimuli.

Minnich has demonstrated clearly that in many orders of insects there are contact chemoreceptors on the tarsi. From this evidence he suggests that, in the prototype of the insect, sense organs capable of detection of chemical stimuli were present on all parts of the body. During the course of evolution a specialisation and localisation of these sensory organs has not improbably occurred. A gradation in the ability to detect taste stimuli would fit in with such a theory.

SUMMARY.

1. Threshold experiments on the contact chemoreceptors show that, taking the extension of the proboscis as the response, the bee responds when a solution of saccharose of an average strength of $M/12$ comes into contact with the antenna. A strength of $M/1$ is required to elicit a response from the fore-tarsus.